

NOTICE: QUANTON CONFIDENTIAL - THIS SHEET CONTAINS PROPRIETARY INFORMATION OF QUANTON INSTRUMENT CO. ANY PERSON ACCEPTING THIS SHEET AND/OR INFORMATION AGREES TO MAKE NO DISCLOSE, USE OR REPRODUCTION THEREOF EXCEPT AS AUTHORIZED IN WRITING BY QUANTON INSTRUMENT CO. AND TO RETURN THIS SHEET TO QUANTON INSTRUMENT CO. ALL RIGHTS RESERVED. © 1989

REV	MODEL	DWG NO.	SIZE	TRENDAL	SCALE	SOURCE	SHEET	OF
-	D	035960	1	NON	NONE	AUTOCAD	2	4

**PRODUCTION**

-001, -002, -004, -005 ASSY



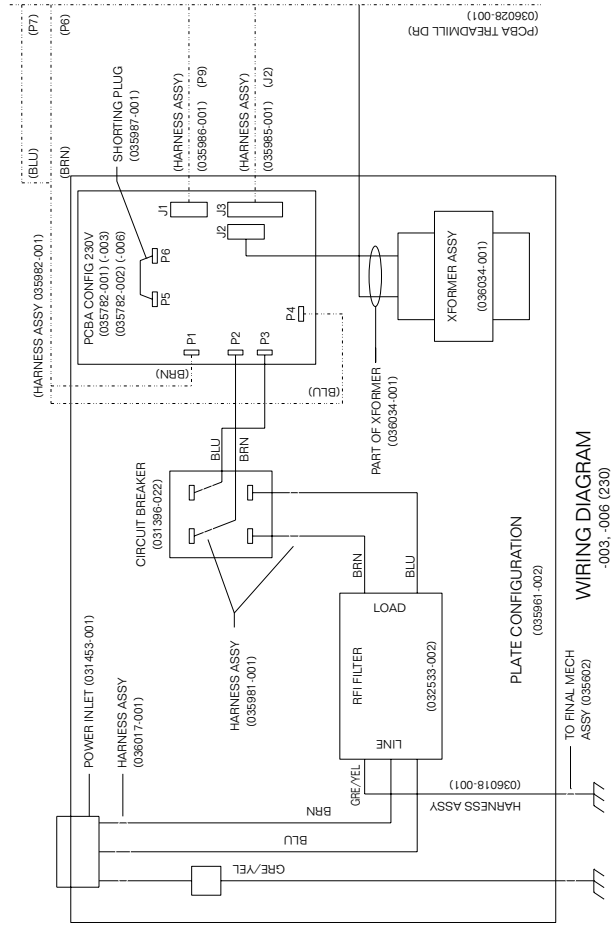
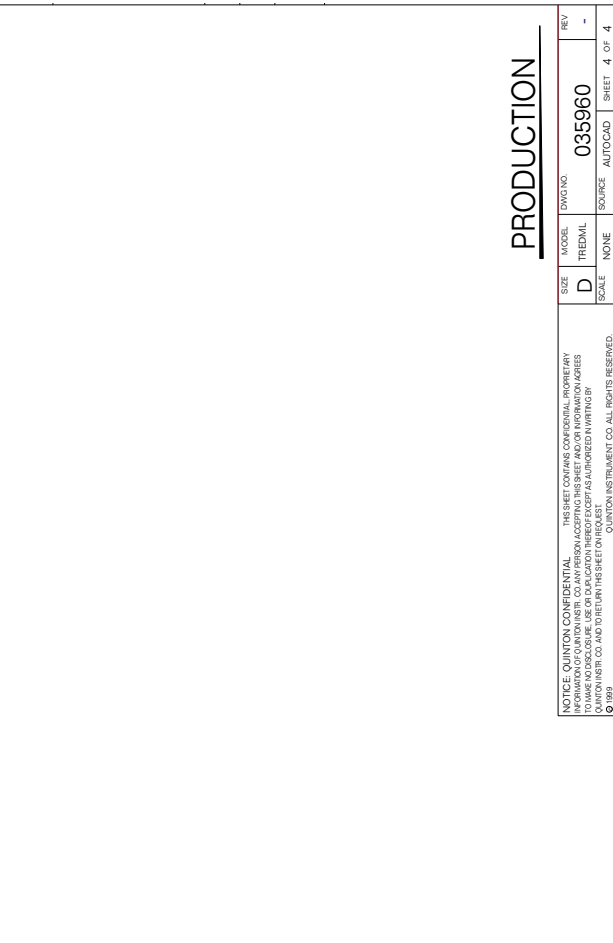
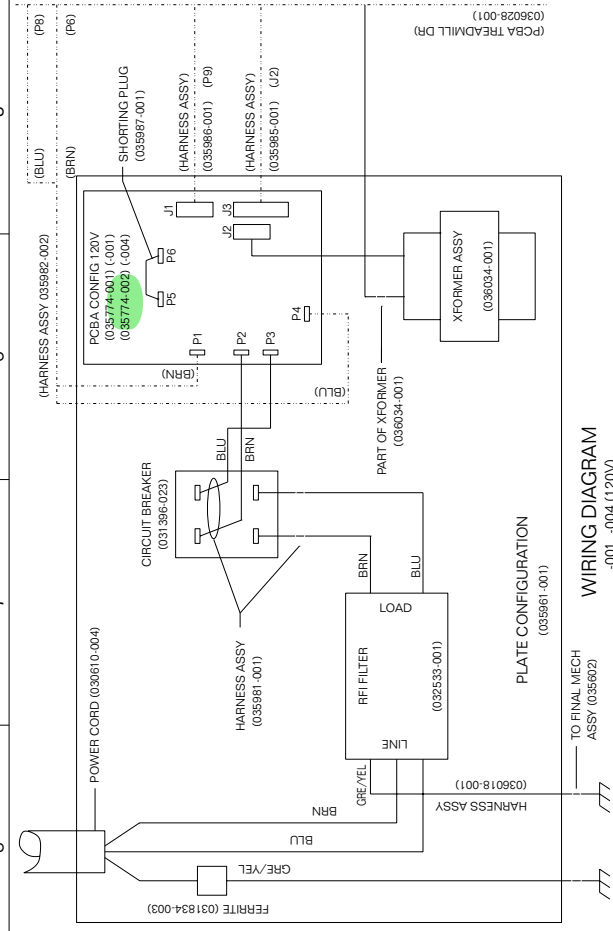
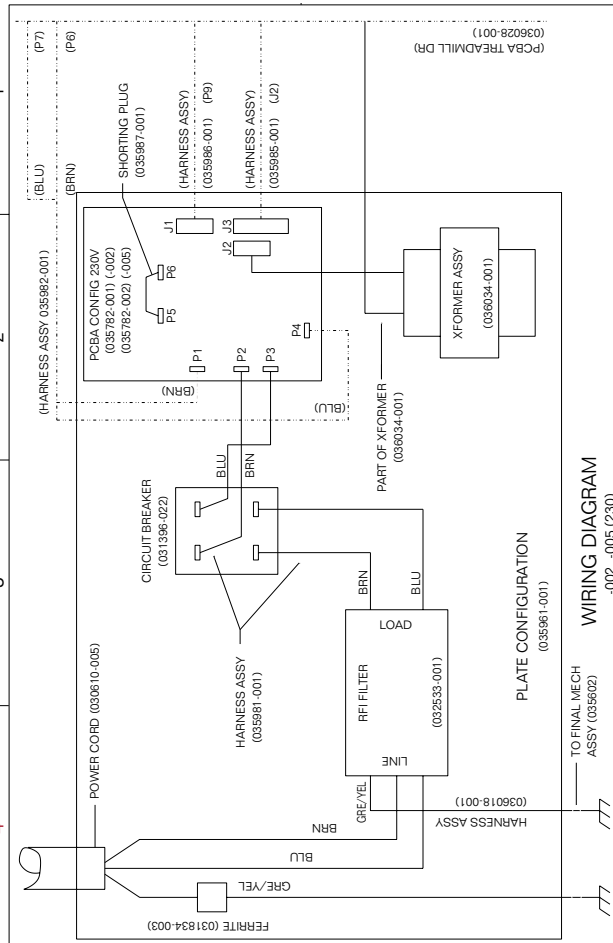

**PRODUCTION**

NOTICE: QUINCY CONFIDENTIAL. THIS SHEET CONTAINS CONFIDENTIAL, PROPRIETARY INFORMATION OF QUINCY INSTRUMENT CO. ANY PERSON ACCEPTING THIS SHEET AND/OR INFORMATION AGREES TO MAINTAIN THE INFORMATION HEREON AS CONFIDENTIAL AND TO RETURN THIS SHEET ON REQUEST.	MODEL	DWG NO.	REV
QUINCY INSTRUMENT CO. ALL RIGHTS RESERVED.	SCALE	TRENDAL	-
© 1999	NONE	SOURCE	AUTOCAD
		SHEET	4 OF 4